

CCT high-pressure/ temperature sensor

For air-conditioning systems with CO₂ heat pump

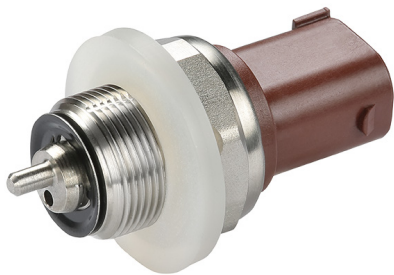

Product description



The CCT high-pressure temperature sensor was specially developed for the high pressures and temperatures in CO₂ heat pumps (R744). Such heat pumps are primarily used in thermal management in vehicles with electric drive (EV). Thanks to its robust stainless steel design, the sensor withstands the high pressures and temperatures in this application.

A digital single-wire interface (LIN) ensures reliable transmission of the pressure and temperature readings. The stainless steel pressure measuring element and the specially developed additional correction function for the temperature readings enable high measuring accuracy for pressure and temperature.

Fields of application

- Air conditioning systems
- Heat pumps with the refrigerant CO₂ (R744)
- Thermal management (battery) in EV

Features

Robust design

- Stainless steel design for high pressure applications
- Special sealing concept to the system

Proven stainless steel measuring element

- Excellent long-term stability
- High fluid compatibility due to the welded design

Temperature measurement directly inside the medium

- Fast response time
- High temperature measurement accuracy is achieved through a special correction function

Application-specific evaluation electronics

- Pressure and temperature signal available via digital single-wire interface (LIN).
- Tried-and-tested automobile EMC/ESD resistance
- Extended diagnostic and protection functions
- Tested LIN 2.0 conformity with energy-saving mode (sleep mode)

Fully automated assembly

- Cost effective
- Large quantities can be produced

CCT high-pressure/ temperature sensor

For air-conditioning systems with CO₂ heat pump



Technical Specifications

Measurement range

Nominal pressure | 0–10 to 0–200 bar

Over pressure | 2 × nominal pressure

Burst pressure | 3 × nominal pressure

Pressure type | Relative

Electrical characteristics

Supply voltage | 9–16 V

Current consumption | max. 10 mA

Output signals | LIN 2.0

Mechanical characteristics

Measuring element | Stainless steel cell with resistive measuring bridge

Housing material | Stainless steel

Pressure connection | HEX 24, M18 × 1

Thread | Male thread

Electrical connection | 3-pin MQS plug

Dimensions

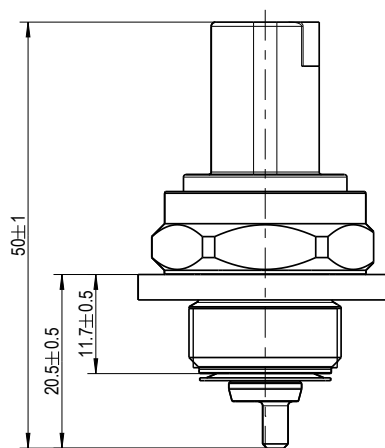

Installation position

Any

Weight

approx. 41 g

Accuracy

Total pressure error | ± 0.5 % FS (0–90 °C)
± 1 % FS (–40–140 °C)

Total temperature error | ± 1 K ¹⁾

Response time (t₉₀) | 3 sec ¹⁾

Environmental conditions

Operating temperature range | –40–140 °C

Media temperature range | –40–165 °C (180 °C)

Media compatibility | R744

¹⁾ Depending on installation situation

